

8.2 WST2 系列中部调压分接开关 WST2 Series of Central Voltage-regulation Tapping Switch

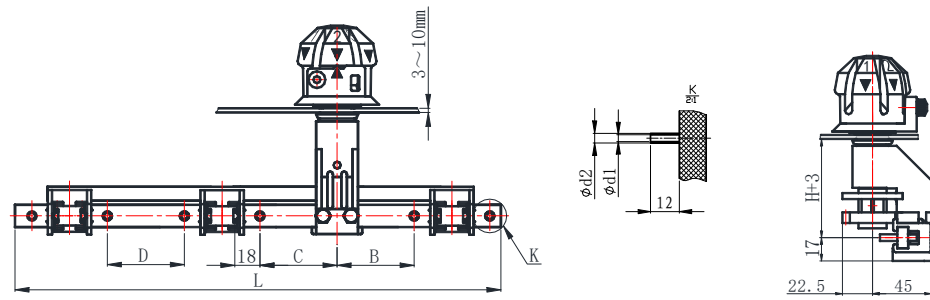

开关型号 Type of tap changer	调压部位 Regulating position	安装尺寸 mm Installation dimension mm							箱盖开孔 Open hole Of box-cover
		L	B	C	D	H	Φd1	Φd2	
WSTII230 / 10 ~ 24-4×3 S	中部 Central	347	55	55	55	70、100、130、150、200 由用户定 (confirmed by user)	φ 2.8	φ 5	φ 20.5+0.5
WSTII230 / 10 ~ 24-6×5 S		455					φ 3.1	φ 5	
WSTII230 / 10 ~ 24-7×6 S		509					φ 4.1	φ 6	
WSTII230 / 10 ~ 24-8×7 S		563							
WSTII230 / 30 ~ 36-8×7 S		678							
WSTII263 / 10 ~ 24-4×3 S		367							
WSTII263 / 10 ~ 24-6×5 S		475							
WSTII263 / 10 ~ 24-7×6 S		529	80	80	120		φ 5.1	φ 7	
WSTII263 / 10 ~ 24-8×7 S		583					φ 3.1	φ 5	
WSTII230 / 30 ~ 36-4×3 S		462					φ 4.1	φ 6	
WSTII230 / 30 ~ 36-6×5 S		570							
WSTII263 / 30 ~ 36-4×3 S		482							
WSTII263 / 30 ~ 36-6×5 S		590							
WSTII263 / 30 ~ 36-8×7 S		698							

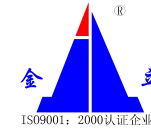

WST₂ 系列无励磁条形分接开关

WST₂-Series of Off-load Strip Tap Switch

使用说明书
Operation Instruction

厂家提醒您注意阅读
Manufacturer reminds
please read carefully

8.3 WST2 系列端部调压分接开关 WST2 Series of End Voltage-regulation Tapping Switch

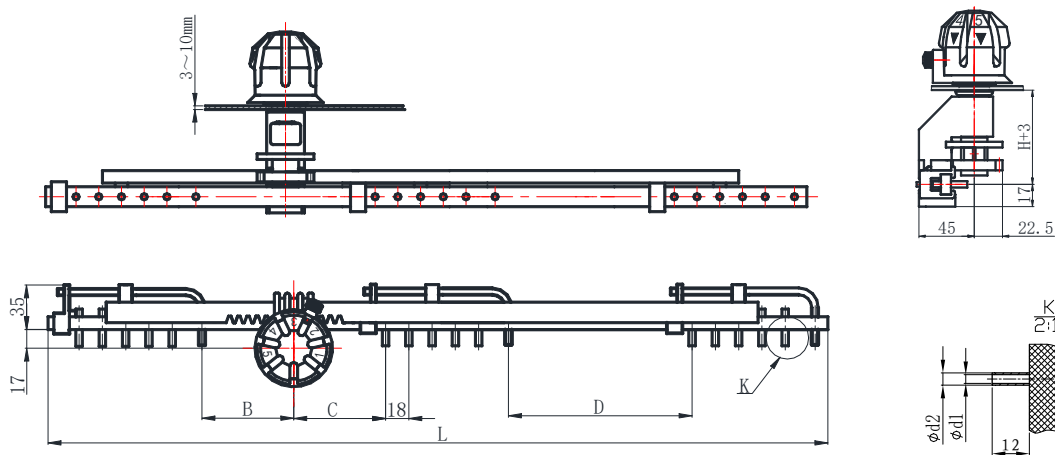

开关型号 Type of tap changer	调压部位 Regulating position	安装尺寸 mm Install dimension mm							箱盖开孔 Open hole of box-cover
		L	B	C	D	H	Φd1	Φd2	
WSTI230 / 10 ~ 20-3×3 S	端部 End section	406	65	65	65	70、100、130、150、200 由用户定 (confirmed by user)	φ 3.1	φ 5	φ 20.5+0.5
WSTI230 / 10 ~ 20-5×5 S		514					φ 4.1	φ 6	
WSTI230 / 10 ~ 20-7×7 S		622							
WSTI263 / 10 ~ 20-3×3 S		406							
WSTI263 / 10 ~ 20-5×5 S		514							
WSTI263 / 10 ~ 20-7×7 S		622							

辽宁金立电力电器有限公司

Liaoning Jinli Electric Power Electrical Appliance Co., Ltd.

地址：辽宁省丹东市振安区同兴镇

Add: Tongxing Village Zhen'an District Dandong, Liaoning, China
电话 Tel: 0415-6134555 (Telephone exchange) 传真 Fax: 0415-6131000

1. 产品用途及使用范围 Application and Service Range of Product

本系列分接开关适用于频率 50Hz, 额定电压等级为 10KV~35KV, 额定通过电流 10A~63A 的油浸式电力变压器中。当需要调整电压时, 必须将变压器从网络上切除。使变压器在无励磁的情况下改变变压器初级线圈匝数, 以实现变压器电压调整的目的。达到调整次级输出电压的目的。

This series of tapping switches are suitable for the oil immersed transformer with frequency 50HZ, rated voltage 10KV~30KV, rated current 10A~63A. When need to regulate voltage, it must have the transformer cut off from coil of transformer. it is changed under no-load condition so as to realize the purpose to regulate the voltage of the transformer and to reach the purpose to regulate the secondary-grade output voltage.

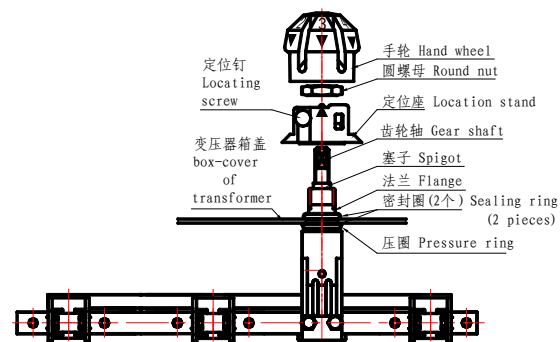
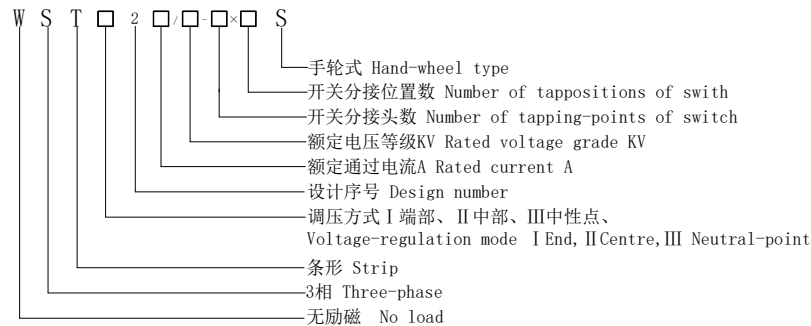

2. 主要技术参数 Major Technical Parameter

额定电压 Rated voltage KV	调压部位 Voltage-Regulation position	接触电阻 contact resistance $\mu\Omega$	工频耐受电压 KV/min power-frequency withstand voltage		
			对地 To earth	相间 Inter-phase	触头间 Inter-contact
10	中性点 Neutral point	$\leq 350 \mu \Omega$	42	10	10
	中部 Central		42	42	18
20~24	中性点 Neutral point		55	20	11
	中部 Central		55	55	20
30~35	中性点 Neutral point		95	35	12
	中部 Central		95	95	25

3. 使用注意事项 Points for attention:

- 使用环境温度: 空气中 $-25^{\circ}\text{C}\sim 40^{\circ}\text{C}$, 油中 $-25^{\circ}\text{C}\sim 100^{\circ}\text{C}$;
- 安装场所应无爆炸和腐蚀性气体;
- 分接开关组装前, 一定要检查分接开关是否符合变压器型号要求, 以免造成不应有的损失;
- 变压器分接引线与分接开关接线端子连接时, 应消除引线拉力, 不得使分接开关受力变形, 且引线与运动部件留有足够的运行间隙, 以免运动阻滞;
- 分接开关最高干燥温度为 $105\pm 5^{\circ}\text{C}$, 如干燥温度过高请于我公司技术部联系。干燥后, 档位转动过紧或过松时, 请将转轴上的塞子调节到适当松紧即可;
- 干燥后如变压器沿转轴渗油, 请将塞子旋紧即可, 如沿箱盖渗油, 请将圆螺母旋紧即可;
- 当开关在极限档位时, 严禁向极限方向用力转动手轮;
- 根据变压器箱盖厚度确定是否需要调节平垫及平垫的个数, 请将调节平垫放置在压圈下面。
- 干燥处理后, 使用分接开关前必须对分接开关的各个固定和移动触点认真进行变压器油润滑。并紧固各紧固件, 防止松动。

- Ambient temperature for using: in air $-25^{\circ}\text{C}\sim 40^{\circ}\text{C}$, in oil $-25^{\circ}\text{C}\sim 100^{\circ}\text{C}$;
- There should be no explosive or corrosive gas in the installation place.
- Before assembling the tapping switch, must check up whether the tapping switch conforms to the type specification of the transformer in order to avoid causing the loss that should not occur.
- When connecting the tap leading wire of the transformer with the connection terminal of the tap switch, shall eliminate the leading wire tension, the tap switch shall not be deformed because of stressing, and the leading wire and the moving part should have enough moving space so as to avoid movement hindered.
- The maximum drying temperature of this switch is $105\pm 5^{\circ}\text{C}$. If the drying temperature is too high, please contact the Technical Department of our company. If after drying, the grade position of the switch turns too tightly or too loosely, please regulate the spigot on the shaft to the suitable degree of tightness.
- If the transformer is leaking oil along the rotary shaft after drying, please revolve the spigot tight. If it is leaking oil along the box cover, please revolve the round nut tight.
- When the switch is at the limit position, strict forbid turning by force the hand-wheel to the limit direction.
- Determine whether it is necessary to adjust the flat pad and the number of flat pads according to thickness of transformer box cover. Please place the adjusting flat pad under the pressure ring.
- After drying treatment, before operating the tap switch, shall lubricate each fixed or moving contacts of the tap switch carefully with transformer oil. And fasten each fixing parts to avoid loosening.

4. 安装 Installation

手轮式分接开关安装时, 特别注意手轮一定要在分接开关中间档位拆、装。先旋出定位钉, 将手轮拔出来, 拧下圆螺母, 取下定位座、密封圈, 并检查密封圈是否完好。将带有一个密封圈的的分接开关从变压器箱盖下穿上来, 再将退下来的零件依次装上去。

When installing the tap switch of hand-wheel type, must be careful to let the hand-wheel be at the middle grade location of the tap switch for disassembling and assembling. First, revolve out the locating screw, pull out the hand-wheel, unscrew the round nut, remove the locating stand, sealing ring and inspect the sealing ring to see if it is perfect or not.

Let the tap switch with a sealing ring pass through from under the box cover of the transformer to the upper face, and assemble all the disassembled parts in turn to it.

5. 操作说明 Operation Explanation

5.1 切勿将手轮拉起! (见图 1.1)

5.1 Do not pull up the handle (See Drawing 1.1)

分接开关在改变开关档位时, 将定位钉旋出到行程的终端, 旋转手轮 (但不要将手轮拉起) 时需稍加用力 (因开关定位器与定位齿轮在旋转时产生了摩擦力, 增加了转动力矩。)到所需的档位后, 微调, 检查并确定手轮上与定位座上的两个箭头相互对准 (见图 1.1)。将定位钉旋入手轮槽口中, 使手轮无法转动 (见图 1.2)。

当开关的调压方式为中性点或端部时, 因开关动触片在每档上只包含一个静触头的特点, 调档位时会有两次到档的感觉。开关调档后检查并确定手轮上与定位座上的两个箭头相互对准 (见图 1.1)。将定位钉旋入手轮槽口中, 使手轮无法转动 (见图 1.2)。

When operating the tap changer with hand feel, changing the tap changer position, screwing out the locating pin to the end of action, only need more strength to rotate the handle(it will make tuning force between located equipment and located gear)(but do not pull up it.)to the position which required, fine-tuning regulation, Check and make sure that two arrows point at same position on handle and locating pin.(See picture 1.1)then screwing the locating pin into the notch of handle, to make the handle could not turn. (See picture 1.2)

Because of the character that each moving-connect nut contain one fixed-connect nut, you will have the hand feeling twice when change the handle and the regulating position is neutral point or end section. After change another position, Check and make sure that two arrows point at each other on handle and locating pin. (See picture 1.1)then screwing the locating pin into the notch of handle to make the handle could not turn. (See picture 1.2)

5.2 如用户需要在分接开关上安装挂锁, 可将挂锁的钩环 (最大 6 毫米) 插入定位座上的长方形孔, 即可用挂锁将手轮锁定在任何位置。

If user need to install padlock on tap changer, can insert the padlock staple(max6mm)into the slot on locating pin, so that can located the handle in any position by padlock.



图 1.1 Drawing 1.1



图 1.2 Drawing 1.2

6. 维护 Maintenance

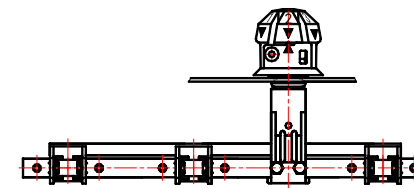
操作必须在变压器完全从电网上切除, 在变压器无励磁的情况下进行。

- 先旋出定位钉, 再往返旋转手轮 5~8 个循环, 然后将手轮旋到需要的分接位置上, 再左右微调手柄几次, 使两个箭头相互对准将定位钉旋入手柄槽口, 对变压器进行直流电阻检测, 以验证其接触可靠性。
- 开关在正常运行时, 为了防止锈蚀保证转动的灵活性, 每两年至少进行一次维护。方法同 6.1。
- 一般故障维护方法。

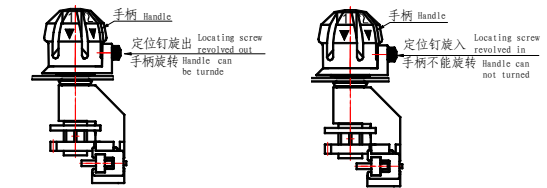
当箱盖密封出现渗油现象时, 应调节圆螺母松紧, 失效时应及时更换“O”型密封圈。当开关轴上出现渗漏油时扭紧调节塞子。

Operation must be carried out under the condition when the transformer is completely cut off from the network, and the transformer has no load.

- First revolve the locating screw out, reciprocate to turn the hand-wheel 5-8 cycles; then turn the hand-wheel to the needed tapping position, make left-right adjusting the handle for several times, Check and make sure that two arrows point at each other on handle and locating pin. revolve the locating screw into the handle slot, test the D.C resistor of transformer to make certain of the contacting reliability.
- When the switch operates normally, shall maintenance once every two years at least so as to prevent rusting and ensure its operating smoothly. The method is the same as 6.1.
- Maintenance Method for General Faults

When appearing oil-leaking on the seal of the cover of box, shall regulate the tightness of the round nut, if it has lost efficacy, shall change “O” Type sealing ring, when appearing oil-leaking on the shaft of the switch, shall screw up the adjusting spigot.

7. 贮存、运输 Storage & Transportation

- 存放在空气流通, 阴凉, 干燥, 无腐蚀性气体的环境中。
- 在运输途中应小心轻放, 严禁冲击, 防水防潮。
- Store in the air-flowing, shady and cool, dry place without corrosive gas.
- In the transportation, shall handle with care, strictly forbid to be impacted, and shall prevent water and wetness.

8. 安装尺寸 Installation Dimension 8.1 WST2 系列中性点调压分接开关 WST2 Series of Neutral-point Voltage-regulation Tapping Switch

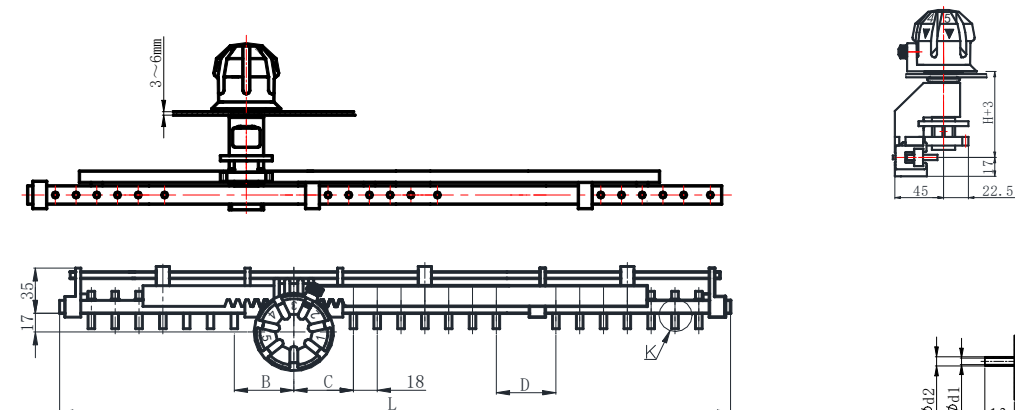

开关型号 Type of tap changer	调压部位 Regulating position	安装尺寸 mm Install dimension mm				箱盖开孔 Open hole of box-cover			
		L	B	C	D				
WST III 230/10~24-3×3 S	中性点 Neutral point	291	45	45	45	70、100、130、 150、200 由用户定 (confirmed by user)	$\phi 3.1$ $\phi 4.1$ $\phi 5.1$ $\phi 7$	$\phi 5$ $\phi 6$ $\phi 7$	$\phi 20.5+0.5$
WST III 230/10~24-5×5 S		399							
WST III 230/10~24-7×7 S		507							
WST III 263/10~24-3×3 S		291							
WST III 263/10~24-5×5 S		399							